



BMP SERIES HYDRAULIC MOTOR

BMP series motor are small volume, economical type, which is designed with shaft distribution flow, which adapt the Gerotor gear set design and provide compact volume, high power and low weight.

Characteristic features:

- * Advanced manufacturing devices for the Gerotor gear set, which provide small volume, high efficiency and long life.
- * Shaft seal can bear high pressure of motor of which can be used in parallel or in series.
- * Advanced construction design, high power and low weight.

Main Specification

Technical data for BMP with 25 and 1 in and 1 in splined and 28.56 tapered shaft

Type		BMP	BMP	BMP	BMP	BMP	BMP	BMP	BMP	BMP	BMP	BMP
		BMPH BMPW 36	BMPH BMPW 50	BMPH BMPW 80	BMPH BMPW 100	BMPH BMPW 125	BMPH BMPW 160	BMPH BMPW 200	BMPH BMPW 250	BMPH BMPW 315	BMPH BMPW 400	BMPH BMPW 500
Geometric displacement (cm ³ /rev.)		36	51.7	77.7	96.2	120.2	157.2	194.5	240.3	314.5	389.5	486.5
Max. speed (rpm)	cont.	1500	1150	770	615	490	383	310	250	192	155	120
	int.	1650	1450	960	770	615	475	385	310	240	190	150
Max. torque (N·m)	cont.	55	100	146	182	236	302	360	380	375	360	385
	int.	76	128	186	227	290	370	440	460	555	525	560
	peak	96	148	218	264	360	434	540	550	650	680	680
Max. output (kW)	cont.	8.0	10.0	10.0	11.0	10.0	10.0	10.0	8.5	7.0	6.0	5.0
	int.	11.5	12.0	12.0	13.0	12.0	12.0	12.0	10.5	8.5	7.0	6.0
Max. pressure drop (MPa)	cont.	12.5	14	14	14	14	14	14	11	9	7	6
	int.	16.5	17.5	17.5	17.5	17.5	17.5	17.5	14	14	10.5	9
	peak	22.5	22.5	22.5	22.5	22.5	22.5	22.5	18	16	14	12
Max. flow (L/min)	cont.	55	60	60	60	60	60	60	60	60	60	60
	int.	60	75	75	75	75	75	75	75	75	75	75
Weight (kg)		5.6	5.6	5.7	5.9	6.0	6.2	6.4	6.7	6.9	7.4	8

* Continuous pressure:Max. value of operating motor continuously.

* Intermittent pressure:Max. value of operating motor in 6 seconds per minute.

* Peak pressure:Max. value of operating motor in 0.6 second per minute.



Main Specification

Technical data for BMP with 31.75 and 32 shaft

Type		BMP 36	BMP 50	BMP 80	BMP 100	BMP 125	BMP 160	BMP 200	BMP 250	BMP 315	BMP 400	BMP 500
Geometric displacement (cm ³ /rev.)		36	51.7	77.7	96.2	120.2	157.2	194.5	240.3	314.5	389.5	486.5
Max. speed (rpm)	cont.	1500	1150	770	615	490	383	310	250	192	155	120
	int.	1650	1450	960	770	615	475	385	310	240	190	150
Max. torque (N·m)	cont.	55	100	146	182	236	302	360	460	475	490	430
	int.	76	128	186	227	290	370	440	570	555	580	560
	peak	96	148	218	264	360	434	540	670	840	840	780
Max. output (kW)	cont.	8.0	10.0	10.0	11.0	10.0	10.0	10.0	8.5	7.0	6.0	6.0
	int.	11.5	12.0	12.0	13.0	12.0	12.0	12.0	10.5	8.5	7.0	7.0
Max. pressure drop (MPa)	cont.	12.5	14	14	14	14	14	14	14	12	9.5	7
	int.	16.5	17.5	17.5	17.5	17.5	17.5	17.5	17.5	14	11.5	9
	peak	22.5	22.5	22.5	22.5	22.5	22.5	22.5	22.5	22.5	18	13
Max. flow (L/min)	cont.	55	60	60	60	60	60	60	60	60	60	60
	int.	60	75	75	75	75	75	75	75	75	75	75
Weight (kg)		5.6	5.6	5.7	5.9	6.0	6.2	6.4	6.7	6.9	7.4	8.0

* Continuous pressure:Max.value of operating motor continuously.

* Intermittent pressure:Max.value of operating motor in 6 seconds per minute .

* Peak pressure:Max.value of operating motor in 0.6 second per minute.

Performance Data

BMP 36 [36cm³/rev.]

Pressure (MPa)		Max.cont.							Max.int.		
		3	6	7	8	10	11	12.5	16.5		

Flow (L/min)	Pressure (MPa)									
	3	6	7	8	10	11	12.5	16.5	Max.cont.	Max.int.
8	13	25	29	34	43	48				
	214	205	200	194	187	179				
15	13	25	29	34	43	48	56	75		
	406	398	391	383	374	366	353	324		
20	13	24	29	34	43	48	56	76		
	541	534	528	521	513	500	486	458		
30	12	24	29	34	43	48	56	76		
	814	804	792	778	763	749	726	701		
35	12	23	28	34	43	48	56	76		
	952	944	930	913	897	879	858	833		
40	12	23	28	32	41	47	55	75		
	1090	1078	1064	1048	1024	998	977	943		
45	11	22	26	32	41	46	54	74		
	1232	1218	1196	1175	1149	1118	1080	1044		
Max.cont.	6	15	22	28	37	44	52	71		
	1505	1494	1480	1466	1438	1406	1367	1309		
Max.int.	3	11	18	20	30	38	49	67		
	1650	1640	1626	1603	1571	1536	1502	1446		

BMP 50 [51.7cm³/rev.]

Pressure (MPa)		Max.cont.							Max.int.		
		3	6	8	10	12.5	14	16	17.5		

Flow (L/min)	Pressure (MPa)									
	3	6	8	10	12.5	14	16	17.5	Max.cont.	Max.int.
8	20	41	56	69	89	95				
	151	134	115	90	56	42				
15	19	40	56	71	91	100	112	120		
	286	274	261	243	204	182	139	102		
20	18	39	55	71	92	101	117	128		
	382	373	361	348	318	309	287	251		
30	17	38	55	71	91	98	116	124		
	573	568	558	535	503	488	462	440		
35	17	38	54	69	89	98	117	124		
	670	661	652	640	606	589	562	548		
45	14	36	53	67	88	98	114	123		
	863	858	849	837	807	788	764	746		
55	12	33	50	65	85	96	111	121		
	1055	1042	1028	1010	979	963	947	920		
Max.cont.	10	32	47	64	83	94	108	119		
	1150	1143	1126	1111	1079	1065	1043	1015		
Max.int.	6	25	42	56	76	87	101	112		
	1440	1430	1416	1395	1367	1351	1335	1312		

BMP 80 [77.7cm³/rev.]

Pressure (MPa)		Max.cont.						Max.int.			
		3	6	8	10	12.5	14	16	17.5		

Flow (L/min)	Pressure (MPa)									
	3	6	8	10	12.5	14	16	17.5	Max.cont.	Max.int.
8	32	62	85	104	129	144				
	97	87	74	55	33	22				
15	32	63	84	107	126	144	165			
	186	181	170	154	132	118	86			
20	31	63	84	107	132	146	168	185		
	251	243	236	225	207	196	178	155		
30	31	62	83	106	131	146	168	186		
	381	379	368	355	332	316	285	263		
35	30	59	81	102	130	144	167	185		
	443	435	426	415	397	383	361	342		
45	25	58	79	100	126	142	165	182		
	570	564	554	543	526	509	483	458		
55	23	57	78	97	124	140	161	179		
	696	685	672	656	643	630	602	579		
Max.cont.	20	53	75	94	120	137	160	177		
	761	753	744	736	720	706	681	660		
Max.int.	14	44	67	87	112	151	169	169		
	948	940	931	920	906	890	871	854		

BMP 100 [96.2cm³/rev.]

Pressure (MPa)		Max.cont.							Max.int.		
		3	6	8	10	12.5	14	16	17.5		

Flow (L/min)	Pressure (MPa)									
	3	6	8	10	12.5	14	16	17.5	Max.cont.	Max.int.
8	40	77	105	130	161	180				
	81	75	69	57	36	24				
15	39	77	106	130	160	180	208			
	152	149	145	140	122	103	81			
20	36	74	104	128	161	179	205	227		
	204	200	195	190	177	166	148	133		
30	33	72	103	125	160	177	203	225		
	308	304	298	290	280	268	255	231		
35	30	70	98	122	159	176	202	224		
	360	352	343	331	320	306	294	275		
45	29	67	95	118	155	174	200	220		
	462	458	451	443	433	419	402	383		
55	25	64	93	116	152	170	198	217		
	566	558	549	540	529	515	498	478		
Max.cont.	22	60	91	114	149	167	194	213		
	618	611	601	589	580	570	558	540		
Max.int.	15	54	83	106	141	160	186	205		
	771	763	755	744	735	724	708	693		

Torque (N·m) 87
Speed (rpm) 920

□ cont.
■ int.

Performance Data

BMP 125 [120.2cm³/rev.]

Pressure (MPa)

				Max.cont.		Max.int.			
		3	6	8	10	12.5	14	16	17.5
Flow (L/min)	8	51	98	137	168	208	236		
		63	60	55	47	28	15		
	15	51	101	138	168	209	236	267	
		121	116	110	102	89	73	48	
	20	48	98	135	167	211	237	269	290
		162	158	153	148	137	128	109	94
	30	46	96	132	164	209	232	264	287
		243	239	234	227	216	202	189	176
	35	42	92	130	160	206	229	260	284
		284	279	274	269	259	247	231	222
45	37	89	125	157	201	224	261	281	
	370	362	355	348	340	327	310	296	
55	33	84	122	152	196	218	252	275	
	452	446	438	431	420	412	402	384	
Max.cont.	60	29	78	117	146	191	215	248	272
		490	482	475	468	459	448	439	427
Max.int.	75	18	66	107	133	179	202	236	260
		615	606	598	586	575	563	549	528

BMP 160 [157.2cm³/rev.]

Pressure (MPa)

				Max.cont.		Max.int.			
		3	6	8	10	12.5	14	16	17.5
Flow (L/min)	8	62	120	170	212	263	290		
		49	48	46	42	26	14		
	15	60	122	172	215	264	294	340	
		93	91	88	85	76	68	48	
	20	57	120	170	214	262	290	340	371
		125	123	120	117	110	106	92	81
	30	53	115	164	206	259	288	335	368
		187	184	181	178	175	168	155	139
	35	49	110	160	202	255	284	328	362
		220	216	213	209	205	202	192	176
45	44	102	154	196	248	278	321	358	
	283	280	276	272	267	260	250	238	
55	40	99	148	191	243	272	316	351	
	345	342	340	336	331	328	320	303	
Max.cont.	60	33	94	144	188	236	267	308	345
		377	374	371	367	363	359	353	342
Max.int.	75	19	80	124	170	216	252	296	325
		473	469	465	459	453	447	440	424

BMP 200 [194.5cm³/rev.]

Pressure (MPa)

				Max.cont.		Max.int.			
		3	6	8	10	12.5	14	16	17.5
Flow (L/min)	8	79	164	207	250	320	360		
		40	39	38	35	28	22		
	15	78	162	205	250	322	361	410	
		76	75	74	71	66	61	51	
	20	76	158	203	247	320	358	403	422
		100	98	97	95	92	89	73	57
	30	70	153	200	245	315	350	398	417
		151	149	147	145	142	139	131	120
	35	66	149	194	232	297	343	386	415
		177	175	173	171	168	166	160	149
45	63	146	190	230	294	340	383	410	
	228	226	224	221	218	215	210	198	
55	54	140	181	224	286	334	371	400	
	280	278	276	274	271	269	263	250	
Max.cont.	60	38	127	164	212	270	325	356	395
		304	302	300	297	294	291	286	272
Max.int.	75	22	96	145	192	235	293	321	367
		382	378	374	371	368	364	360	350

BMP 250 [240.3cm³/rev.]

Pressure (MPa)

				Max.cont.		Max.int.			
		3	6	8	10	12.5	14	16	17.5
Flow (L/min)	8	96	190	268	326	403			
		30	28	24	21	11			
	15	98	194	270	327	405	450	510	
		60	58	54	50	40	30	12	
	20	92	188	267	325	405	456	514	565
		82	80	77	76	69	64	52	38
	30	85	180	259	320	400	448	513	561
		123	120	118	114	106	98	87	76
	35	77	176	252	311	389	436	504	557
		143	141	139	135	128	122	112	101
45	70	168	243	300	377	428	495	543	
	185	182	178	174	168	161	152	139	
55	63	159	237	290	369	417	483	531	
	226	223	218	213	209	202	193	185	
Max.cont.	60	60	150	228	280	358	407	473	520
		248	246	243	239	233	226	215	207
Max.int.	75	34	128	202	264	342	387	448	488
		309	306	302	297	292	286	278	264

□ cont.
■ int.

Torque (N·m) 128
Speed (rpm) 306



Performance Data

BMP 315 [314.5cm³/rev.]

Pressure (MPa)		Max.cont.		Max.int.		
3	5	7	9	10	12.5	14

Flow (L/min)	Pressure (MPa)						Max.cont.	Max.int.
	3	5	7	9	10	12.5		
8	123 25	215 23	292 21	368 17	405 11			
15	118 47	211 46	287 44	367 40	404 28	495 21	568 10	
20	110 62	205 61	278 60	360 57	395 46	494 40	566 36	
30	101 94	196 93	271 91	349 88	388 76	490 68	565 65	
35	96 109	188 107	264 106	341 104	382 96	478 89	557 84	
45	89 141	180 140	254 138	337 135	372 127	468 120	553 115	
55	76 173	166 172	239 170	325 167	362 160	457 152	548 143	
Max.cont. 60	65 188	154 186	227 184	308 182	348 178	443 172	529 163	
Max.int. 75	40 236	120 234	201 232	279 228	323 226	418 223	497 214	

BMP 400 [389.5cm³/rev.]

Pressure (MPa)		Max.cont.		Max.int.		
3	4.5	5.5	6.5	8	10	12.5

Flow (L/min)	Pressure (MPa)						Max.cont.	Max.int.
	3	4.5	5.5	6.5	8	10		
8	166 20	232 19	287 18	340 16	418 12			
15	165 38	228 36	277 35	337 33	417 31	496 27	612 21	
20	162 50	223 49	273 49	331 48	413 45	495 41	608 35	
30	154 76	216 75	266 74	318 73	405 71	486 67	600 60	
35	146 88	210 87	256 87	312 86	395 83	480 80	588 75	
45	132 114	197 113	243 112	300 110	383 108	464 106	576 99	
55	117 139	184 137	227 136	283 135	363 135	450 132	552 123	
Max.cont. 60	102 153	163 152	215 150	272 148	347 146	436 143	532 138	
Max.int. 75	53 191	128 189	182 187	234 185	318 183	391 180	484 176	

Torque (N·m) 234
Speed (rpm) 185

BMP500[486.5cm³/rev.]

Pressure (MPa)		Max.cont.		Max.int.		
1.5	3	4.5	6	7	8	9

Flow (L/min)	Pressure (MPa)						Max.cont.	Max.int.
	1.5	3	4.5	6	7	8		
4	96 7	194 6	285 4					
8	98 15	201 15	304 14	391 14	443 12	512 9	574 7	
15	96 30	192 30	284 29	380 28	421 26	496 23	550 22	
20	96 40	191 40	280 40	372 39	418 37	493 33	546 31	
30	91 61	185 60	272 60	360 58	412 56	486 53	541 50	
40	86 81	172 80	261 80	343 79	408 76	480 73	538 70	
50	78 102	160 101	241 100	332 98	391 96	466 93	528 90	
Max.cont. 60	66 122	134 121	213 120	305 119	371 117	438 114	496 110	
70	52 143	111 142	189 141	292 139	344 137	418 135	475 131	
Max.int. 75	35 153	83 152	154 151	241 150	312 149	389 147	448 144	

cont.
int.

Torque (N·m) 389
Speed (rpm) 147

BMP DIMENSIONS AND MOUNTING DATA

MOUNTING

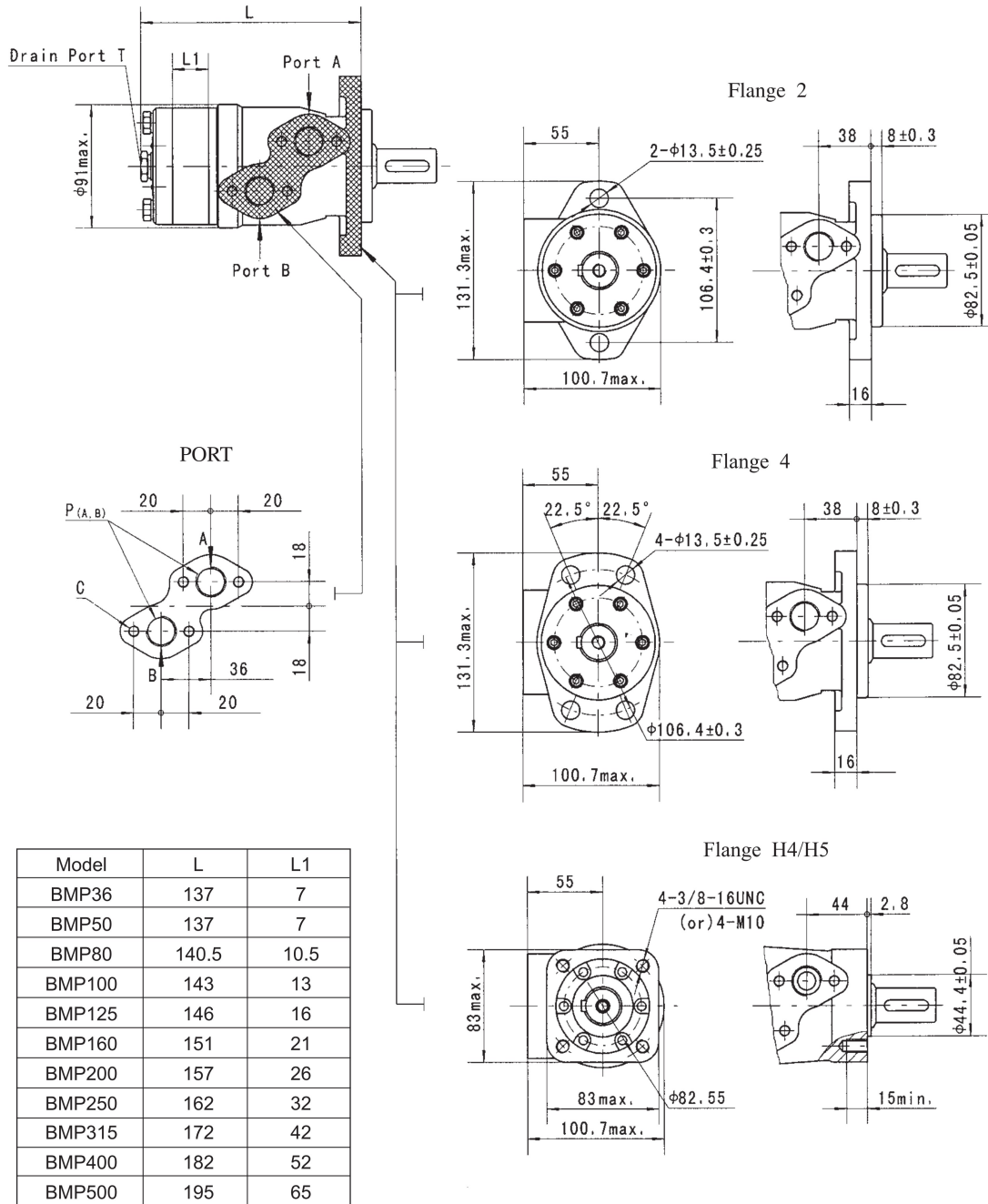

Code	D (depth)	M (depth)	S (depth)	P (depth)	R (depth)
P(A,B)	G1/2 (15)	M22 x 1.5 (15)	7/8-14 O-ring (17)	1/2-14NPTF (15)	PT(RC)1/2 (15)
C	4-M8 (13)	4-M8 (13)	4-5/16-18UNC(13)	4-5/16-18UNC(13)	4-M8 (13)
T	G1/4 (12)	M14 x 1.5 (12)	7/16-20UNF (12)	7/16-20UNF (12)	PT(RC)1/4 (9.7)



BMPH DIMENSIONS AND MOUNTING DATA

MOUNTING

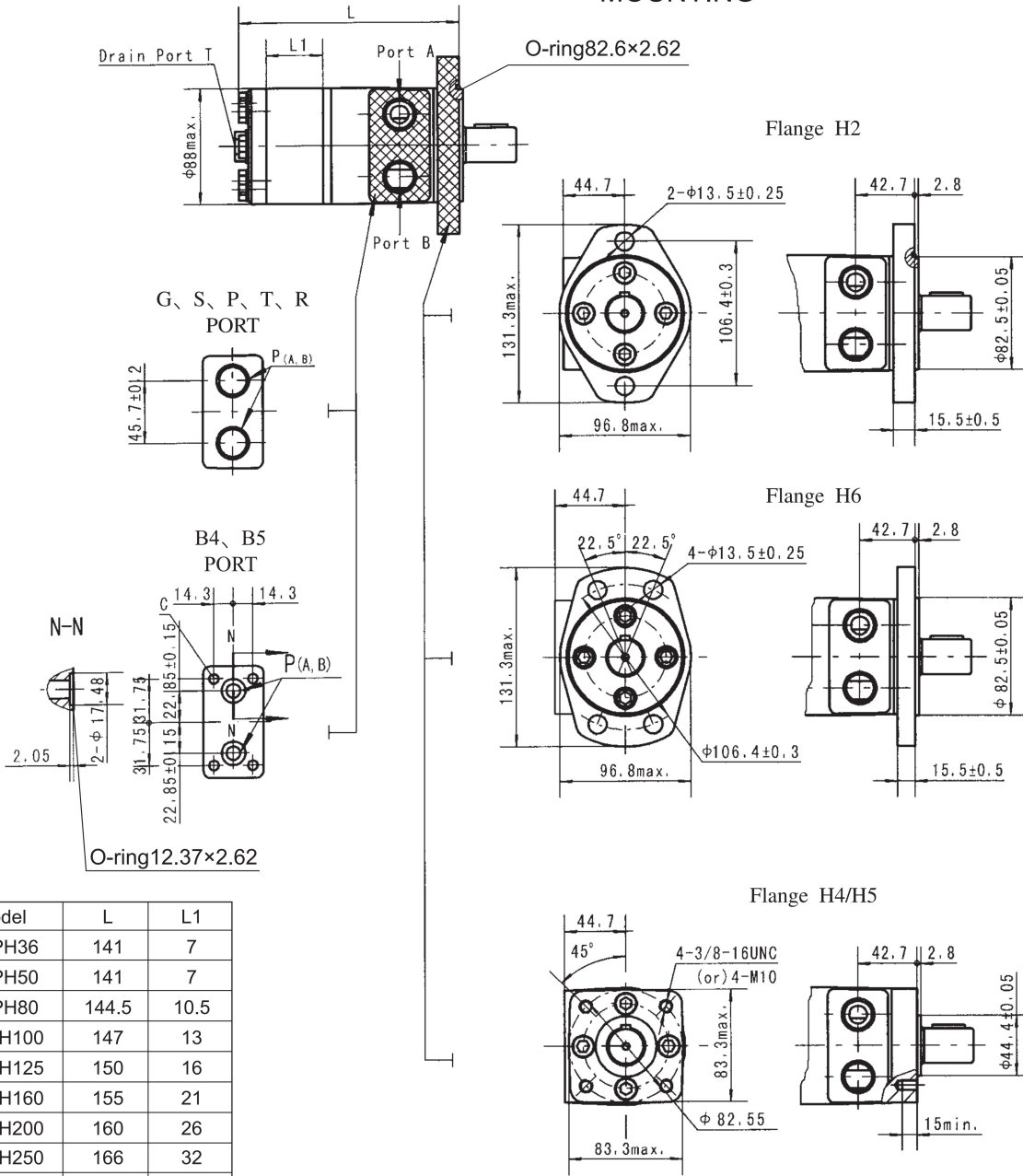

Model	L	L1
BMPH36	141	7
BMPH50	141	7
BMPH80	144.5	10.5
BMPH100	147	13
BMPH125	150	16
BMPH160	155	21
BMPH200	160	26
BMPH250	166	32
BMPH315	176	42
BMPH400	186	52
BMPH500	199	65

Note: The size L of the BMPH N1 should be increased by 2mm.

Code	G (depth)	S (depth)	P (depth)	T (depth)	R (depth)	B4 (depth)	B5 (depth)
P(A,B)	G1/2 (15)	7/8-14 O-ring (17)	1/2-14NPTF (15)	3/4-16 O-ring (15)	PT(RC)1/2 (15)	ø10	ø10
T	G1/4 (12)	7/16-20UNF (12)	7/16-20UNF (12)	7/16-20UNF(12)	PT(RC)1/4 (9.7)	7/16-20UNF(12)	G1/4(12)
C	-	-	-	-	-	4-5/16-18UNC(13)	4-M8(13)

BMP SHAFT EXTENSIONS DIMENSIONS DATA

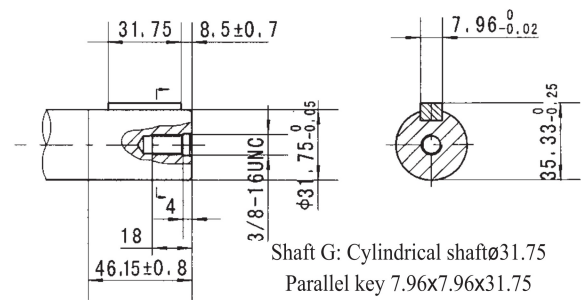
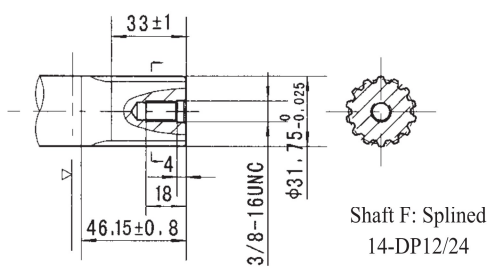
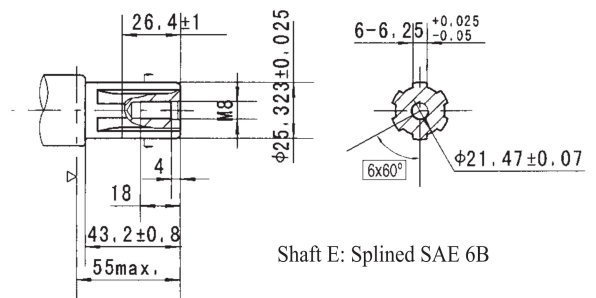
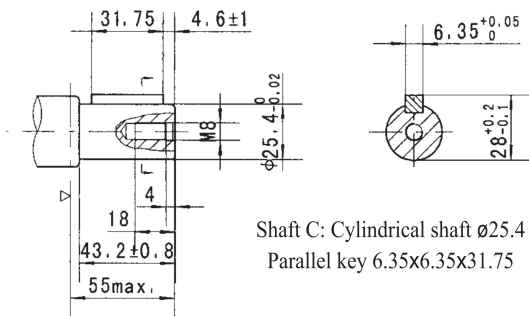
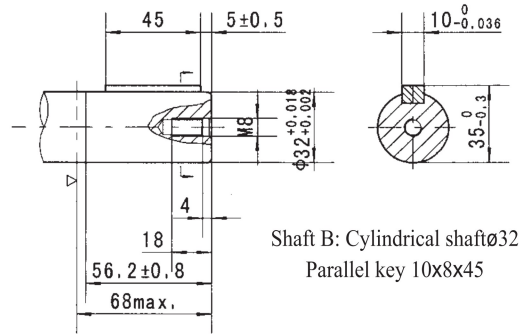
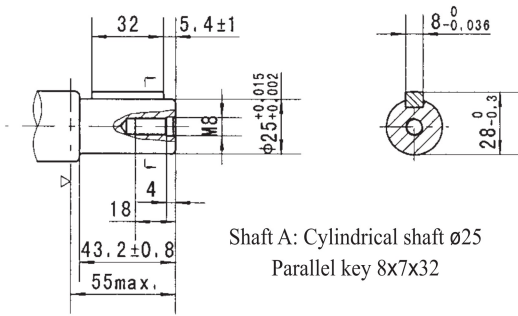

▷ Motor Mounting Surface

BMP SHAFT EXTENSIONS DIMENSIONS DATA

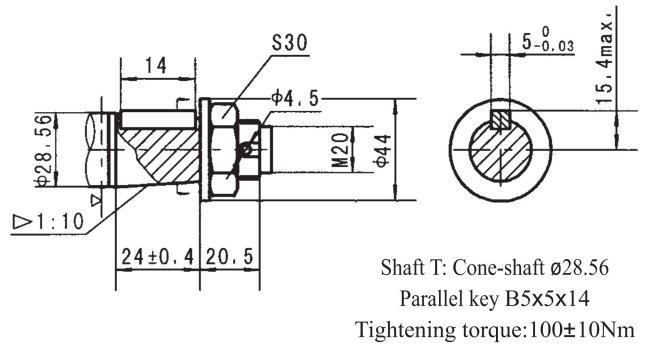
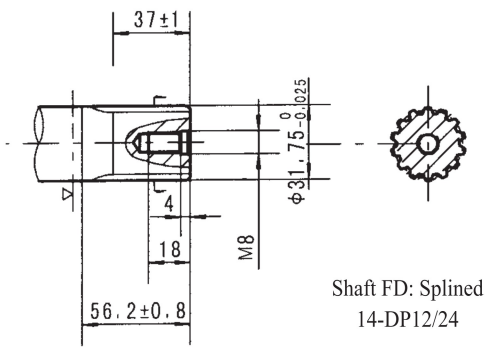
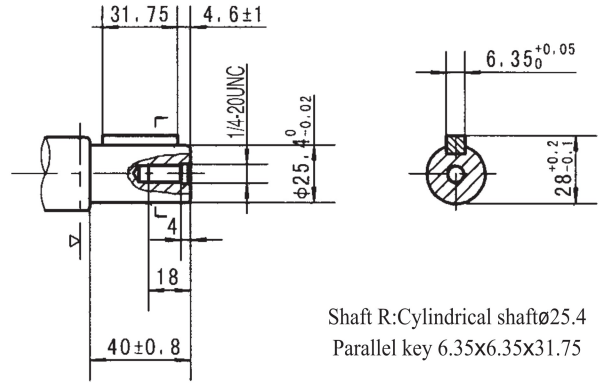
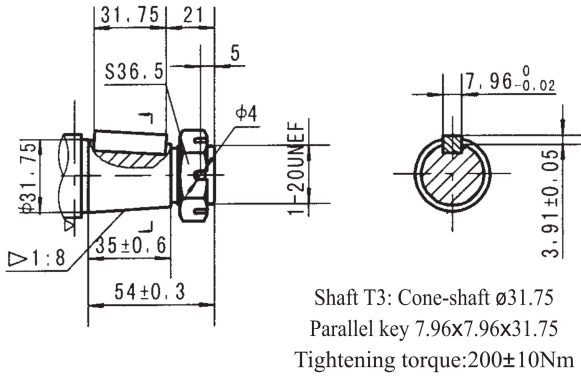

▷ Motor Mounting Surface

BMPH SHAFT EXTENSIONS DIMENSIONS DATA

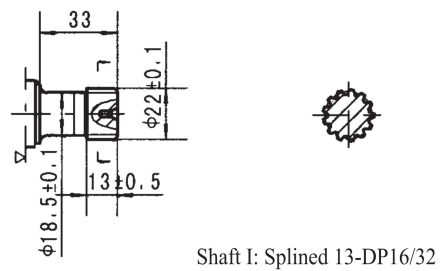
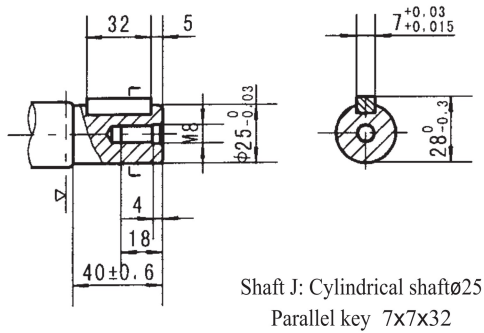
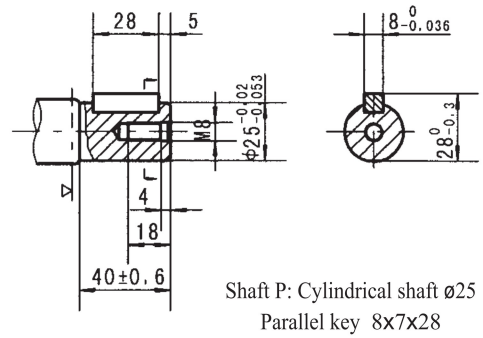
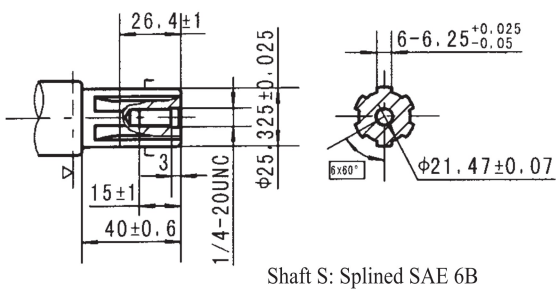
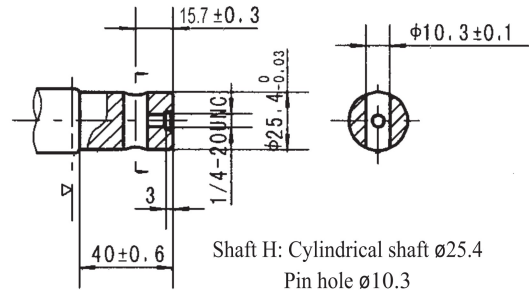
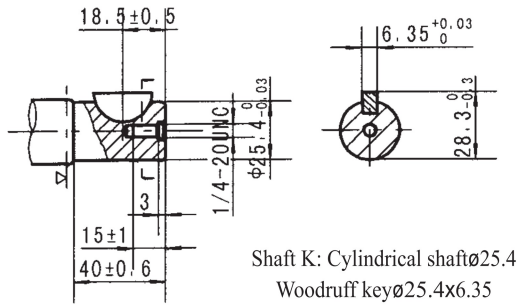

▷ Motor Mounting Surface

BMPH SHAFT EXTENSIONS DIMENSIONS DATA

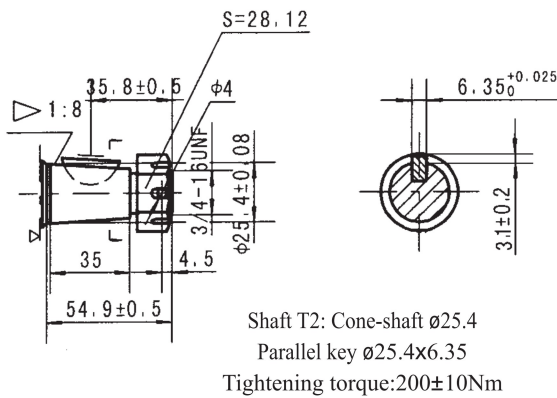
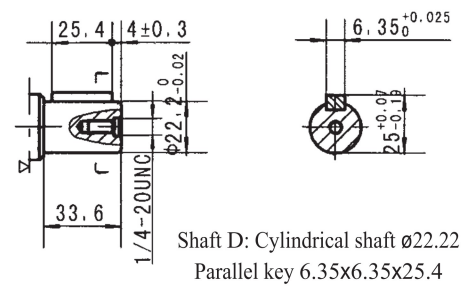
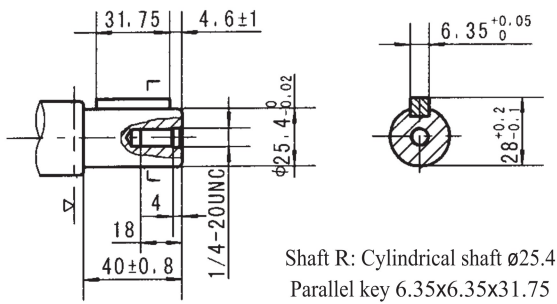
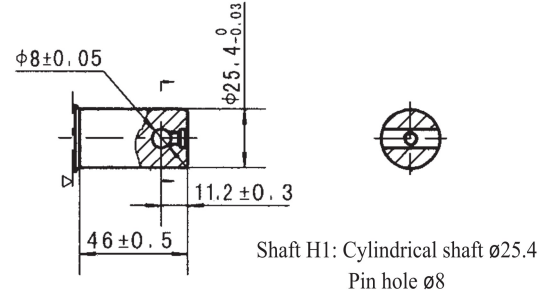
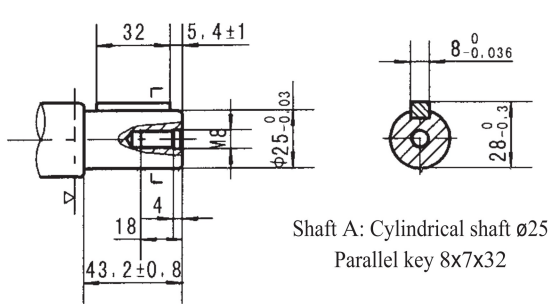

▷ Motor Mounting Surface

BMP、BMPH Series Hydraulic Motor

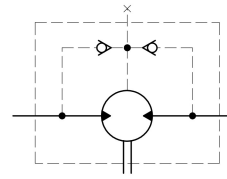

Permissible shaft seal pressure

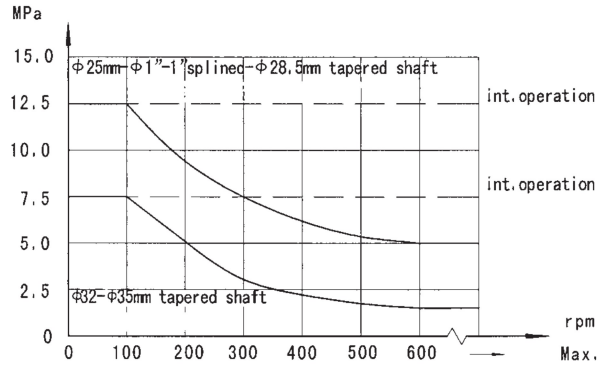
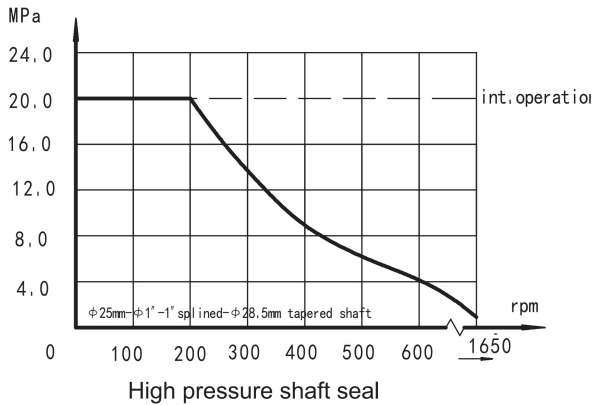

In applications without drain line, output shaft seal exceeds a bit of the pressure in the return line. When applications use the drain line, the pressure of output shaft seal equals the pressure in drain line.

Direction of shaft rotation: Standard

When facing shaft end of motor, shaft to rotate:
Clockwise when port "A" is pressurized.
Counter-clockwise port "B" is pressurized.

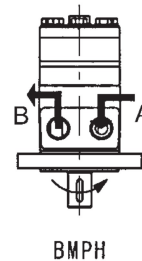
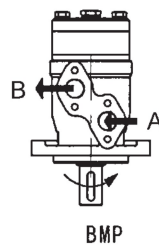

**Status of the shaft's radial force
(Standard motor with journal bearing)**

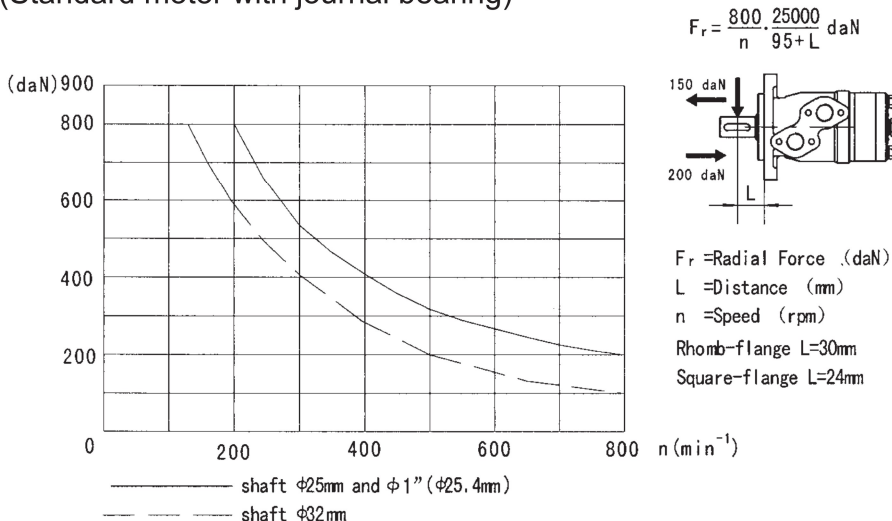

Oil flow in drain line

The table shows the Max. oil flow in the drain line at a return pressure less than 0.5-1MPa.

Pressure drop (MPa)	Viscosity (mm ² /s)	Oil flow in the drain line (L/min.)
10	20	2.5
	35	1.8
14	20	3.5
	35	2.8